

- NOTES:
- A. FOR REFERENCE ONLY UNLESS PROPERLY ENDORSED. FOR ADDITIONAL DETAILS AND SPECIFICATIONS, CONSULT FACTORY.
  - B. DIMENSIONS ARE IN INCHES [MILLIMETERS].
  - C. HATCHED AREA INDICATES PERMISSIBLE CONDUIT ENTRANCE AREA.
  - D. FANS, FILTERS, LEG STANDS OR CLOSING PLATES ARE SUPPLIED WHEN OPTION MIX NECESSITATES.
  - E. USE APPROPRIATE TYPE RATED HUBS OR FITTINGS TO MAINTAIN ENCLOSURE RATING.

david\_dahlman Tuesday, May 10, 2016 9:54:56 AM

REVISIONS				
REV.	DESCRIPTION	ECR#	DRAWN BY	DATE
03	DIMENSIONS CORRECTED.	6641	DSD	5/10/16
02	ADDED NEW LEG DETAILS.	4493	JDE	9/13/13

**YASKAWA**

THIS DOCUMENT AND INFORMATION CONTAINED IN IT ARE CONFIDENTIAL, AND CANNOT BE COPIED OR DISCLOSED IN WHOLE OR IN PART WITHOUT THE EXPRESS WRITTEN CONSENT OF YASKAWA AMERICA INC.

DRAWN: D. Packer	DATE 07/01/2012	TITLE: DIMENSION DRAWING, A&P 1000, TYPE 3R, W2	
CHECKED: D. Cmelak	DATE 07/01/2012	MATERIAL#	
TECH:	DATE	SIZE A	REVISION 03
APPROVED: K. Flierl	DATE 07/01/2012	PAGE 1 OF 2	
ORIGINAL DESIGN: D. Packer	DATE 07/01/2012	DRAWING #: DD.AP1.3R.W2.01	

# LEG STAND MOUNTING OPTION DIMENSIONS

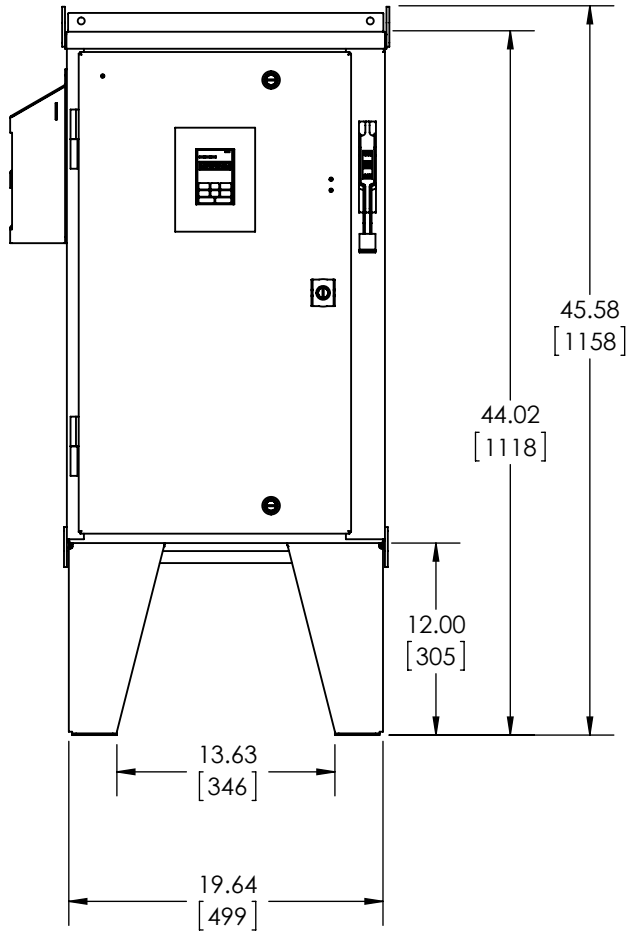

**12.0" HIGH LEGS**

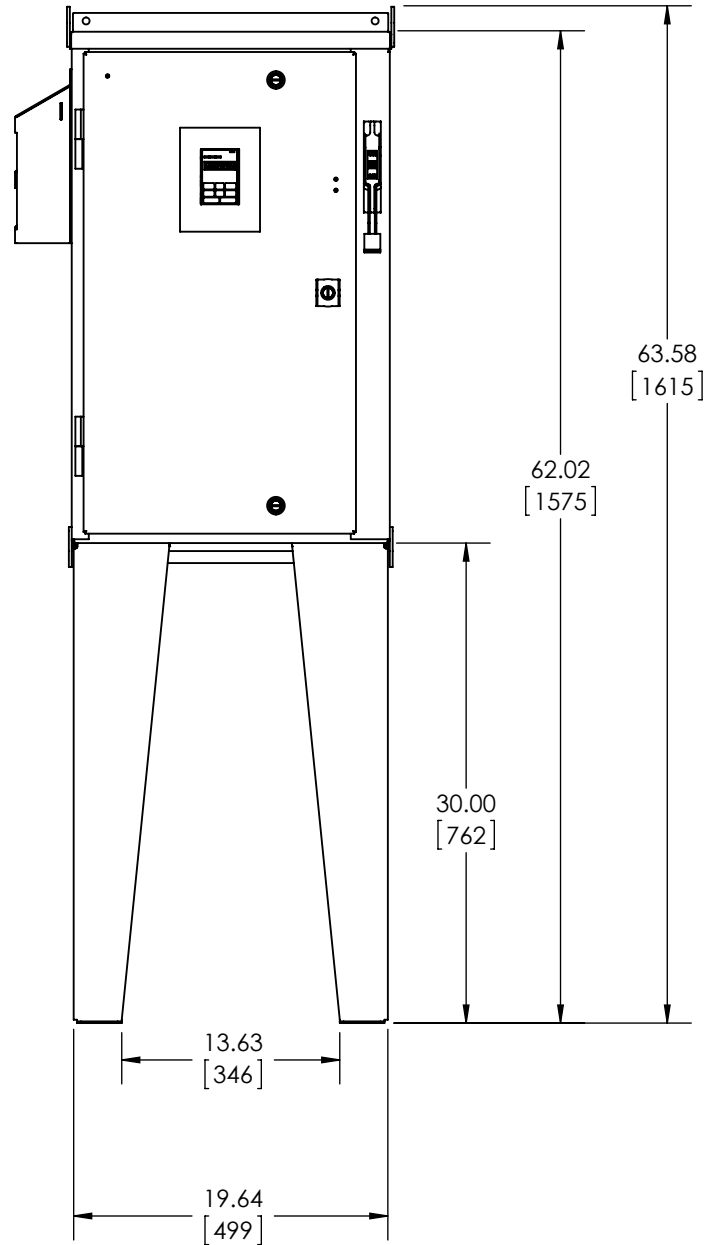

**30.0" HIGH LEGS**

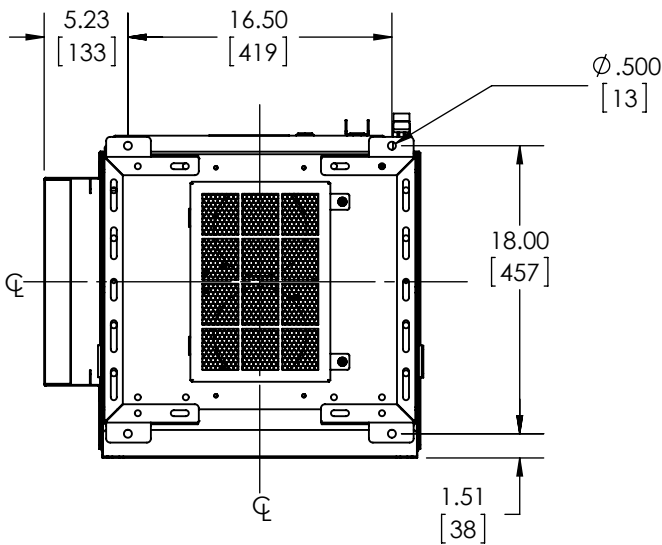

**NOTE: DRILL PATTERN SAME FOR 12" AND 30" HIGH LEGS**

david\_dahlman Tuesday, May 10, 2016 9:54:56 AM

 <p><i>THIS DOCUMENT AND INFORMATION CONTAINED IN IT ARE CONFIDENTIAL, AND CANNOT BE COPIED OR DISCLOSED IN WHOLE OR IN PART WITHOUT THE EXPRESS WRITTEN CONSENT OF YASKAWA AMERICA INC.</i></p>	DRAWN: <b>D. Packer</b>	DATE 07/01/2012	TITLE: DIMENSION DRAWING, A&P 1000, TYPE 3R, W2		
	CHECKED: <b>D. Cmelak</b>	DATE 07/01/2012			
	APPROVED: <b>K. Flierl</b>	DATE 07/01/2012	SIZE A	REVISION 03	PAGE 2 OF 2
	ORIGINAL DESIGN: <b>D. Packer</b>	DATE 07/01/2012	DRAWING #: DD.AP1.3R.W2.01		